

Main Product Characteristics

$V_{(BR)DSS}$	40V
$R_{DS(ON)}$	50m Ω (Max.)
I_D	5A

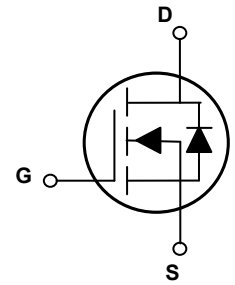
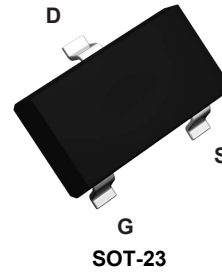

Schematic Diagram

Features and Benefits

- Advanced MOSFET process technology
- Ideal for high efficiency switched mode power supplies
- Low on-resistance with low gate charge
- Fast switching and reverse body recovery



Description

The GSFC4050 utilizes the latest techniques to achieve high cell density and low on-resistance. These features make this device extremely efficient and reliable for use in high efficiency switch mode power supplies and a wide variety of other applications.

Absolute Maximum Ratings ($T_C=25^\circ\text{C}$ unless otherwise specified)

Parameter	Symbol	Max.	Unit
Drain-Source Voltage	V_{DS}	40	V
Gate-Source Voltage	V_{GS}	± 20	V
Drain Current-Continuous, $T_C=25^\circ\text{C}$	I_D	5	A
Drain Current-Continuous, $T_C=100^\circ\text{C}$		3	
Drain Current-Pulsed ¹	I_{DM}	20	A
Power Dissipation, $T_C=25^\circ\text{C}$	P_D	1.4	W
Power Dissipation - Derate Above 25 $^\circ\text{C}$		11.2	
Thermal Resistance, Junction-to-Ambient	$R_{\theta JA}$	80	$^\circ\text{C}/\text{W}$
Operating Junction Temperature Range	T_J	-55 To +150	$^\circ\text{C}$
Storage Temperature Range	T_{STG}	-55 To +150	$^\circ\text{C}$

Electrical Characteristics ($T_J=25^\circ\text{C}$ unless otherwise specified)

Parameter	Symbol	Conditions	Min.	Typ.	Max.	Unit
On / Off Characteristics						
Drain-Source Breakdown Voltage	$V_{(BR)DSS}$	$V_{GS}=0V, I_D=250\mu A$	40	-	-	V
BV_{DSS} Temperature Coefficient	$\Delta BV_{DSS}/\Delta T_J$	Reference to 25°C , $I_D=1mA$	-	0.04	-	$V/^\circ\text{C}$
Drain-Source Leakage Current	I_{DSS}	$V_{DS}=40V, V_{GS}=0V,$ $T_J=25^\circ\text{C}$	-	-	1	μA
		$V_{DS}=32V, V_{GS}=0V,$ $T_J=125^\circ\text{C}$	-	-	10	μA
Gate-Source Leakage Current	I_{GSS}	$V_{GS}=\pm 20V, V_{DS}=0V$	-	-	± 100	nA
Static Drain-Source On-Resistance ³	$R_{DS(ON)}$	$V_{GS}=10V, I_D=4A$	-	35	50	m Ω
		$V_{GS}=4.5V, I_D=2A$	-	45	62	m Ω
Forward Transconductance	g_{fs}	$V_{DS}=10V, I_D=3A$	-	6	-	S
Gate Threshold Voltage	$V_{GS(th)}$	$V_{GS}=V_{DS}, I_D=250\mu A$	1.1	1.6	2.9	V
$V_{GS(th)}$ Temperature Coefficient	$\Delta V_{GS(th)}$		-	-4	-	mV/ $^\circ\text{C}$
Dynamic and Switching Characteristics						
Total Gate Charge ^{2,3}	Q_g	$V_{DS}=20V, I_D=3A$ $V_{GS}=4.5V$	-	4.9	8	nC
Gate-Source Charge ^{2,3}	Q_{gs}		-	0.48	1	
Gate-to-Drain Charge ^{2,3}	Q_{gd}		-	1.72	3.2	
Turn-On Delay Time ^{2,3}	$t_{d(on)}$	$V_{DD}=20V, R_G=25\Omega$ $V_{GS}=4.5V, I_D=1A$	-	3.7	6	nS
Rise Time ^{2,3}	t_r		-	8.8	16	
Turn-Off Delay Time ^{2,3}	$t_{d(off)}$		-	20	36	
Fall Time ^{2,3}	t_f		-	8	12	
Input Capacitance	C_{iss}	$V_{DS}=25V, V_{GS}=0V,$ $F=1MHz$	-	422	800	pF
Output Capacitance	C_{oss}		-	66	120	
Reverse Transfer Capacitance	C_{rss}		-	41	80	
Drain-Source Diode Characteristics and Maximum Ratings						
Continuous Source Current	I_S	$V_G=V_D=0V,$	-	-	5	A
Pulsed Source Current ³	I_{SM}	Force Current	-	-	10	A
Diode Forward Voltage ³	V_{SD}	$V_{GS}=0V, I_S=2A$ $T_J=25^\circ\text{C}$	-	-	1.2	V
Reverse Recovery Time	T_{rr}	$V_{GS}=0V, I_S=1A,$ $di/dt=100A/\mu s,$	-	20	-	nS
Reverse Recovery Charge	Q_{rr}	$T_J=25^\circ\text{C}$	-	7.5	-	nC

Note:

1. Repetitive rating: Pulsed width limited by maximum junction temperature.
2. Pulse test: pulse width $\leq 300\mu s$, duty cycle $\leq 2\%$.
3. Essentially independent of operation temperature.

Typical Electrical and Thermal Characteristic Curves

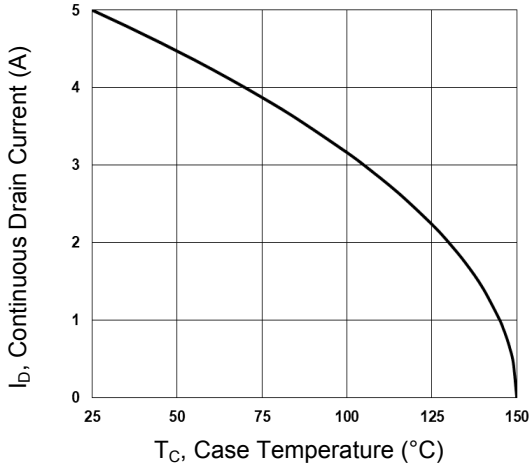

Figure 1. Continuous Drain Current vs. T_c

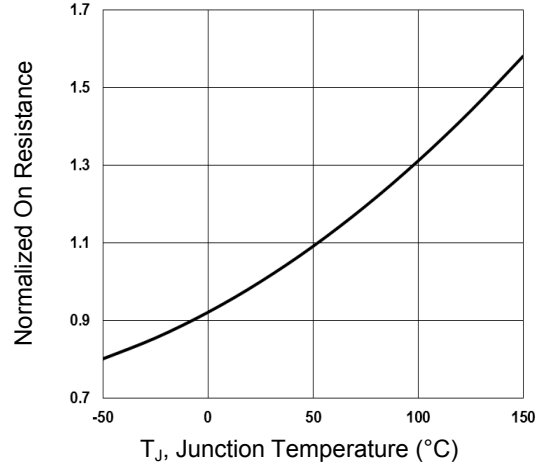

Figure 2. Normalized $R_{DS(on)}$ vs. T_j

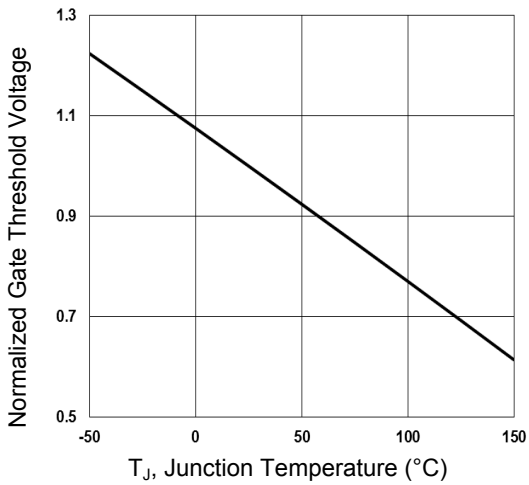

Figure 3. Normalized V_{th} vs. T_j

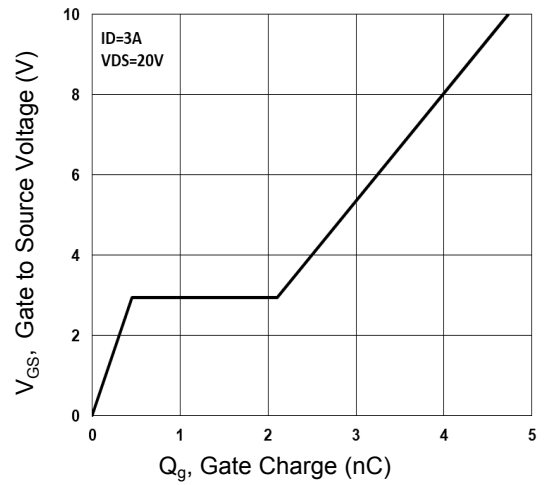

Figure 4. Gate Charge Waveform

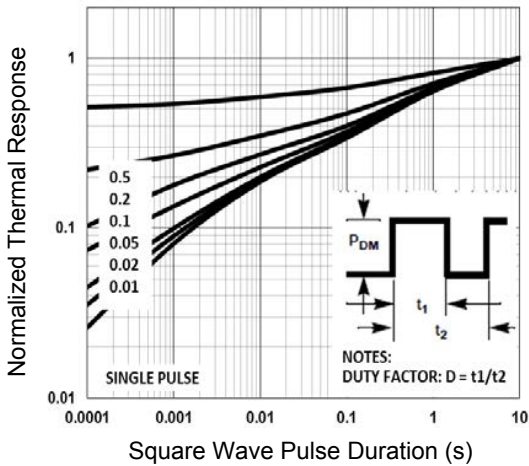

Figure 5. Normalized Transient Response

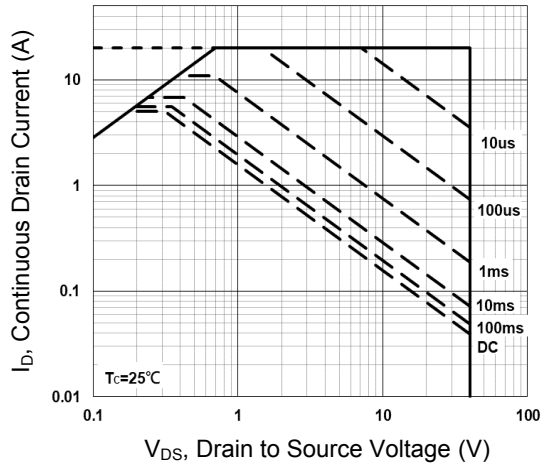
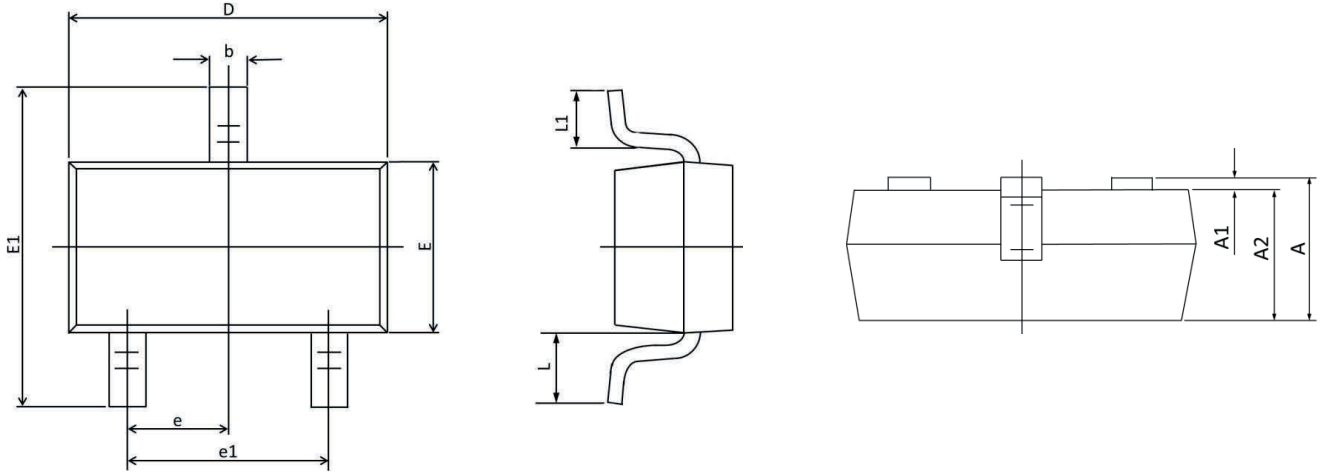

Figure 6. Maximum Safe Operation Area

Package Outline Dimensions (SOT-23)



Symbol	Dimensions In Millimeters		Dimensions In Inches	
	Min	Max	Min	Max
A	0.900	1.200	0.035	0.047
A1	0.000	0.100	0.000	0.004
A2	0.900	1.150	0.035	0.045
b	0.300	0.500	0.012	0.020
D	2.800	3.040	0.110	0.120
E	1.200	1.400	0.047	0.055
E1	2.250	2.550	0.089	0.100
e	0.95 TYP.		0.037 TYP.	
e1	1.800	2.000	0.071	0.079
L	0.55 REF.		0.022 REF.	
L1	0.300	0.500	0.012	0.020

Order Information

Device	Package	Marking	Carrier	Quantity
GSFC4050	SOT-23	C4050	Tape & Reel	3,000pcs / Reel

For more information, please contact us at: inquiry@goodarksemi.com