

Main Product Characteristics

BV_{DSS}	200V
$R_{DS(ON)}$	24mΩ (Max)
I_D	72A

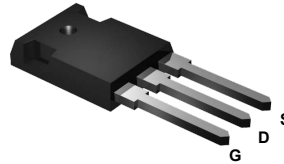

TO-247

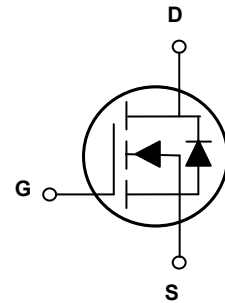

Schematic Diagram

Features and Benefits

- Advanced MOSFET process technology
- Ideal for high efficiency switched mode power supplies
- Low on-resistance with low gate charge
- Fast switching and reverse body recovery



Description

The GSFA2072 utilizes the latest techniques to achieve high cell density and low on-resistance. These features make this device extremely efficient and reliable for use in high efficiency switch mode power supplies and a wide variety of other applications.

Absolute Maximum Ratings ($T_J=25^{\circ}\text{C}$ unless otherwise specified)

Parameter	Symbol	Max.	Unit
Drain-Source Voltage	V_{DS}	200	V
Gate-Source Voltage	V_{GS}	± 20	V
Drain Current-Continuous @ Steady-State ($T_C=25^{\circ}\text{C}$)	I_D	72	A
Drain Current-Continuous @ Steady-State ($T_C=100^{\circ}\text{C}$)		45	
Drain Current-Pulsed ($T_C=25^{\circ}\text{C}$) ¹	I_{DM}	288	A
Single Pulse Avalanche Energy	E_{AS}	140	mJ
Single Pulse Avalanche Current	I_{AS}	53	A
Power Dissipation ($T_C=25^{\circ}\text{C}$) ²	P_D	250	W
Thermal Resistance, Junction-to-Ambient (PCB Mounted, Steady-State)	$R_{\theta JA}$	50	$^{\circ}\text{C/W}$
Thermal Resistance, Junction-to-Case	$R_{\theta JC}$	0.5	$^{\circ}\text{C/W}$
Operating Junction Temperature Range	T_J	-55 To +150	$^{\circ}\text{C}$
Storage Temperature Range	T_{STG}	-55 To +150	$^{\circ}\text{C}$

Electrical Characteristics ($T_J=25^{\circ}\text{C}$ unless otherwise specified)

Parameter	Symbol	Conditions	Min.	Typ.	Max.	Unit
On / Off Characteristics						
Drain-Source Breakdown Voltage	BV_{DSS}	$V_{GS}=0V, I_D=250\mu A$	200	-	-	V
Drain-Source Leakage Current	I_{DSS}	$V_{DS}=200V, V_{GS}=0V, T_J=25^{\circ}\text{C}$	-	-	1	μA
		$V_{DS}=200V, V_{GS}=0V, T_J=125^{\circ}\text{C}$	-	10	-	μA
Gate-Source Leakage Current	I_{GSS}	$V_{GS}=\pm 20V, V_{DS}=0V$	-	-	± 100	nA
Static Drain-Source On-Resistance	$R_{DS(ON)}$	$V_{GS}=10V, I_D=46A$	-	19.4	24	m Ω
Gate Threshold Voltage	$V_{GS(th)}$	$V_{GS}=V_{DS}, I_D=250\mu A$	3.0	-	5.0	V
Dynamic and Switching Characteristics						
Total Gate Charge ^{3,4}	Q_g	$V_{DD}=100V, I_D=46A, V_{GS}=10V$	-	36	-	nC
Gate-Source Charge ^{3,4}	Q_{gs}		-	22	-	
Gate-Drain ("Miller") Charge ^{3,4}	Q_{gd}		-	4.3	-	
Gate Plateau ^{3,4}	$V_{plateau}$		-	6.9	-	V
Turn-On Delay Time ^{3,4}	$t_{d(on)}$	$V_{DD}=100V, R_G=2.5\Omega, V_{GS}=10V, I_D=46A$	-	22	-	nS
Rise Time ^{3,4}	t_r		-	80	-	
Turn-Off Delay Time ^{3,4}	$t_{d(off)}$		-	34	-	
Fall Time ^{3,4}	t_f		-	9.6	-	
Input Capacitance	C_{iss}	$V_{DS}=25V, V_{GS}=0V, F=1\text{MHz}$	-	2655	-	pF
Output Capacitance	C_{oss}		-	1593	-	
Reverse Transfer Capacitance	C_{rss}		-	37	-	
Gate Resistance	R_g	$F=1\text{MHz}$	-	4.4	-	Ω
Drain-Source Diode Characteristics and Maximum Ratings						
Continuous Source Current (Body Diode)	I_S	$T_C=25^{\circ}\text{C}$, MOSFET symbol showing the integral reverse p-n junction diode.	-	-	72	A
Diode Pulsed Current	$I_{S,pulse}$		-	-	288	A
Diode Forward Voltage	V_{SD}	$V_{GS}=0V, I_S=46A$	-	-	1.4	V
Reverse Recovery Time ³	t_{rr}	$I_S=46A, V_{GS}=0V, di_f/dt=100A/\mu s$	-	128	-	nS
Reverse Recovery Charge ³	Q_{rr}		-	0.59	-	μC

Note:

1. Pulse time $5\mu s$.
2. The dissipated power value will change with the temperature. When it is greater than 25°C , the dissipated power will decrease by $1.67W/^{\circ}\text{C}$ for every 1 degree of temperature rise.
3. Pulse test: pulse width $\leq 300\mu s$, duty cycle $\leq 2\%$.
4. Essentially independent of operating temperature.

Typical Electrical and Thermal Characteristic Curves

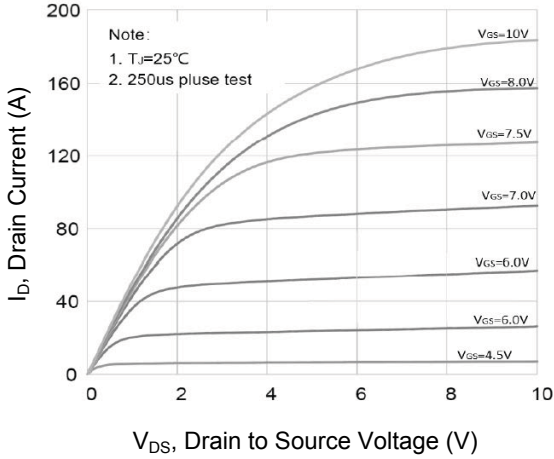

Figure 1. Typical Output Characteristics

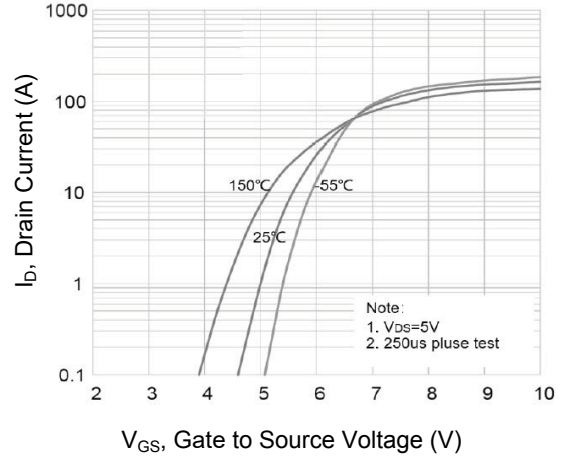

Figure 2. Transfer Characteristics

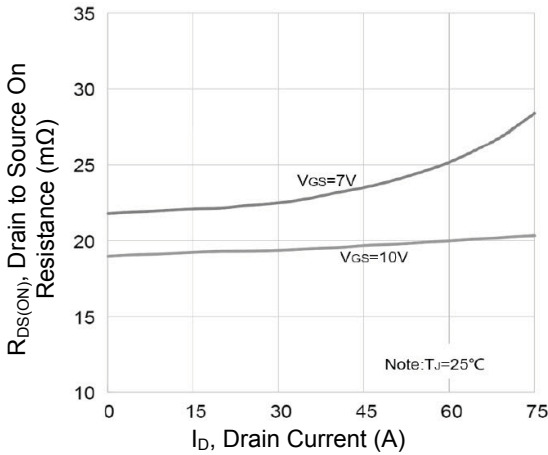

Figure 3. $R_{DS(ON)}$ vs. Drain Current

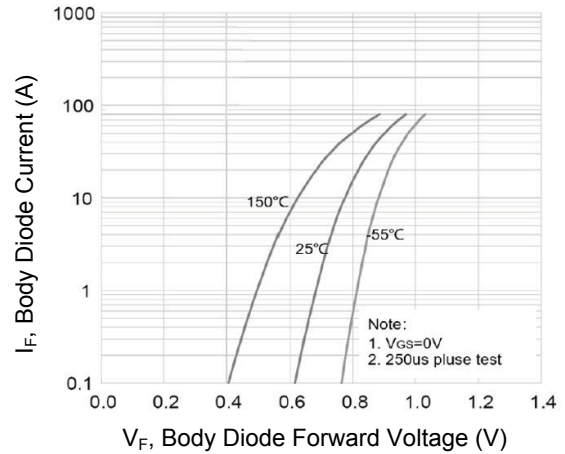

Figure 4. Body Diode Characteristics

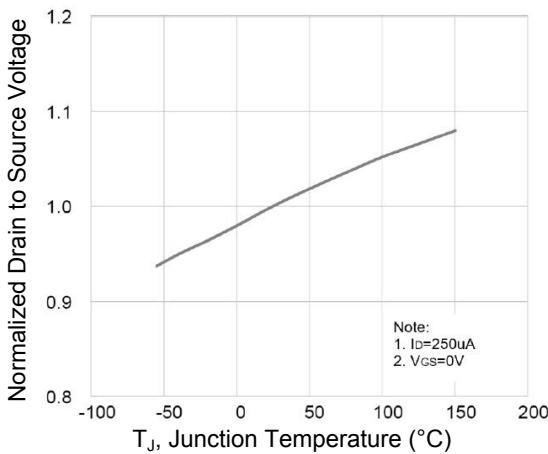

Figure 5. Normalized BV_{DSS} vs. Junction Temperature

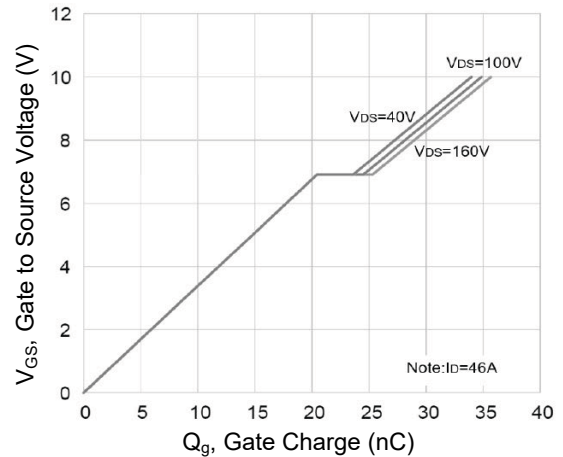

Figure 6. Gate Charge

Typical Electrical and Thermal Characteristic Curves

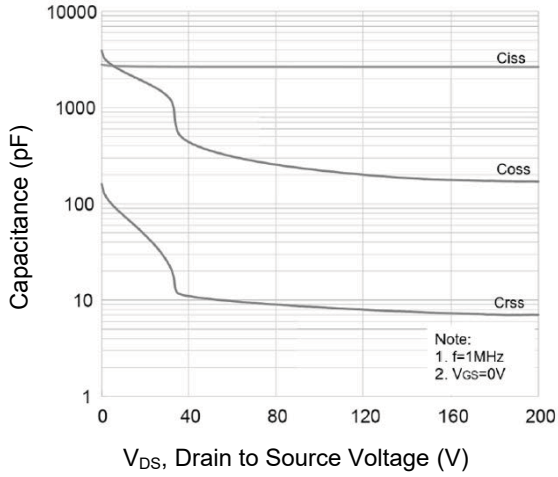

Figure 7. Capacitance Characteristics

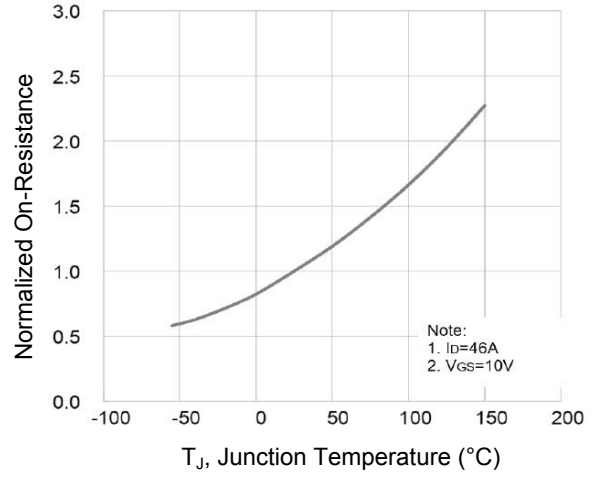

Figure 8. Normalized $R_{DS(ON)}$ vs. T_J

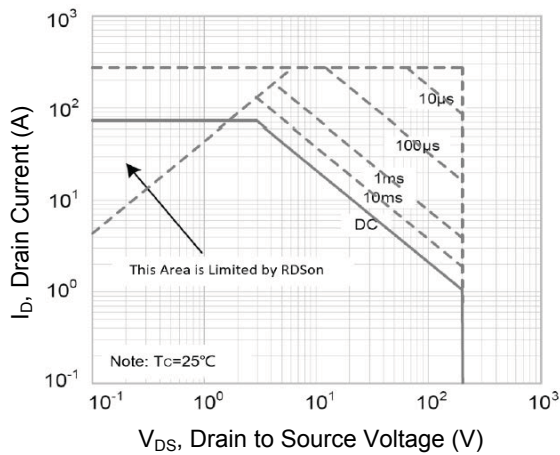
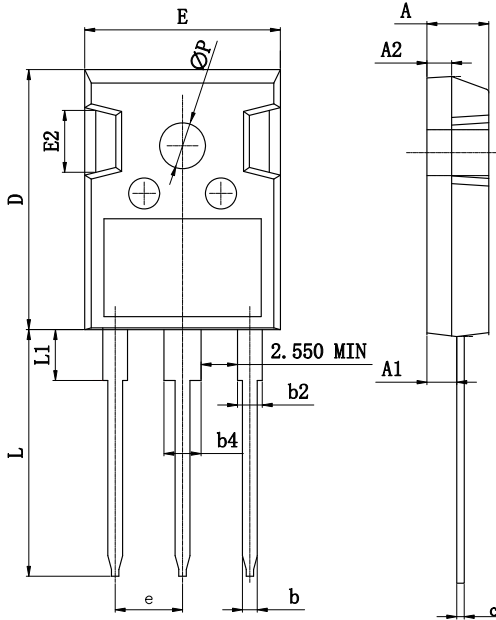

Figure 9. Safe Operation Area

Package Outline Dimensions (TO-247)



Symbol	Dimensions In Millimeters		Dimensions In Inches	
	Min.	Max.	Min.	Max.
A	4.75	5.20	0.187	0.205
A1	2.21	2.65	0.087	0.104
A2	1.85	2.15	0.073	0.085
b	1.00	1.36	0.039	0.054
b2	1.80	2.25	0.071	0.089
b4	2.91	3.25	0.115	0.128
c	0.51	0.75	0.020	0.030
D	20.80	21.30	0.819	0.839
E	15.50	16.10	0.610	0.634
E2	4.40	5.20	0.173	0.205
e	5.44 BSC		0.214 BSC	
L	19.72	20.22	0.776	0.796
L1	-	4.30	-	0.169
P	3.40	3.80	0.134	0.150

Order Information

Device	Package	Marking	Carrier	Quantity
GSFA2072	TO-247	A24020	Tube	30pcs / Tube

For more information, please contact us at: inquiry@goodarksemi.com