

Main Product Characteristics

BV_{DSS}	100V
$R_{DS(ON)}$	4.3m Ω (Max)
I_D	136A

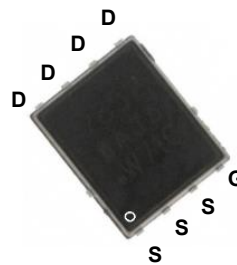

PPAK5x6

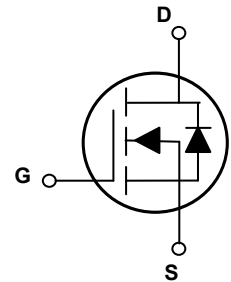

Schematic Diagram

Features and Benefits

- Advanced MOSFET process technology
- Ideal for high efficiency switched mode power supplies
- Low on-resistance with low gate charge
- Fast switching and reverse body recovery



Description

The GSFP4R310 utilizes the latest techniques to achieve high cell density and low on-resistance. These features make this device extremely efficient and reliable for use in high efficiency switch mode power supplies and a wide variety of other applications.

Absolute Maximum Ratings ($T_A=25^\circ\text{C}$ unless otherwise specified)

Parameter	Symbol	Max.	Unit
Drain-Source Voltage	V_{DS}	100	V
Gate-Source Voltage	V_{GS}	± 20	V
Drain Current-Continuous, @ Steady-State ($T_C=25^\circ\text{C}$)	I_D	136	A
Drain Current-Continuous, @ Steady-State ($T_C=100^\circ\text{C}$)		88	
Drain Current-Pulsed ($T_C=25^\circ\text{C}$) ¹	I_{DM}	544	A
Single Pulse Avalanche Energy	E_{AS}	289	mJ
Single Pulse Avalanche Current	I_{AS}	34	A
Power Dissipation ($T_C=25^\circ\text{C}$) ²	P_D	147	W
Thermal Resistance, Junction-to-Ambient (PCB Mounted, Steady-State)	$R_{\theta JA}$	50	$^\circ\text{C/W}$
Thermal Resistance, Junction-to-Case	$R_{\theta JC}$	0.85	$^\circ\text{C/W}$
Operating Junction Temperature Range	T_J	-55 To +150	$^\circ\text{C}$
Storage Temperature Range	T_{STG}	-55 To +150	$^\circ\text{C}$
Soldering Temperature (SMD)	T_{SOLD}	260	$^\circ\text{C}$

Electrical Characteristics ($T_A=25^\circ\text{C}$ unless otherwise specified)

Parameter	Symbol	Conditions	Min.	Typ.	Max.	Unit
On / Off Characteristics						
Drain-Source Breakdown Voltage	BV_{DSS}	$V_{GS}=0V, I_D=250\mu A$	100	-	-	V
Drain-Source Leakage Current	I_{DSS}	$V_{DS}=100V, V_{GS}=0V, T_J=25^\circ\text{C}$	-	-	1.0	μA
		$V_{DS}=100V, V_{GS}=0V, T_J=125^\circ\text{C}$	-	2.0	-	μA
Gate-Source Forward Leakage	I_{GSS}	$V_{GS}=\pm 20V, V_{DS}=0V$	-	-	± 100	nA
Static Drain-Source On-Resistance	$R_{DS(ON)}$	$V_{GS}=10V, I_D=50A$	-	3.3	4.3	m Ω
Gate Threshold Voltage	$V_{GS(th)}$	$V_{GS}=V_{DS}, I_D=250\mu A$	2.1	-	3.9	V
Dynamic and Switching Characteristics						
Total Gate Charge ^{3,4}	Q_g	$V_{DD}=50V, I_D=50A, V_{GS}=10V$	-	62	-	nC
Gate-Source Charge ^{3,4}	Q_{gs}		-	30	-	
Gate-Drain ("Miller") Charge ^{3,4}	Q_{gd}		-	9.2	-	
Gate to Plateau ^{3,4}	$V_{plateau}$		-	5.8	-	V
Turn-On Delay Time ^{3,4}	$t_{d(on)}$	$V_{DD}=50V, R_G=3\Omega, V_{GS}=10V, I_D=50A$	-	32	-	nS
Rise Time ^{3,4}	t_r		-	95	-	
Turn-Off Delay Time ^{3,4}	$t_{d(off)}$		-	60	-	
Fall Time ^{3,4}	t_f		-	26	-	
Input Capacitance	C_{iss}	$V_{DS}=50V, V_{GS}=0V, F=1\text{MHz}$	-	4755	-	pF
Output Capacitance	C_{oss}		-	630	-	
Reverse Transfer Capacitance	C_{rss}		-	18	-	
Gate Resistance	R_g	$F=1\text{MHz}$	-	3.3	-	Ω
Drain-Source Diode Characteristics and Maximum Ratings						
Continuous Source Current (Body Diode)	I_S	MOSFET symbol showing the integral reverse p-n junction diode.	-	-	136	A
Pulsed Source Current	$I_{S,pulse}$		-	-	544	A
Diode Forward Voltage	V_{SD}	$V_{GS}=0V, I_S=50A$	-	-	1.4	V
Reverse Recovery Time ³	t_{rr}	$V_{GS}=0V, V_R=50V, I_S=50A, dI_F/dt=100A/\mu s$	-	59	-	nS
Reverse Recovery Charge ³	Q_{rr}		-	98	-	nC

Note:

1. Pulse time of 5 μs .
2. The dissipated power value will change with the temperature. When it is greater than 25 $^\circ\text{C}$, the dissipated power value will decrease by 0.55 $^\circ\text{C}/\text{W}$ for every 1 degree of temperature increase.
3. Pulse test: Pulse width $\leq 300\mu s$, duty cycle $\leq 2\%$.
4. Basically unaffected by operating temperature.

Typical Electrical and Thermal Characteristic Curves

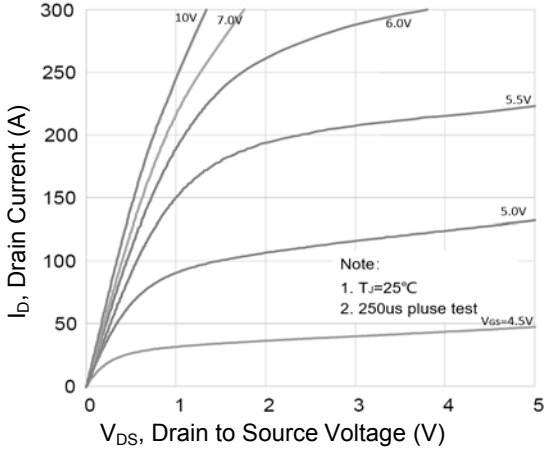

Figure 1. Typical Output Characteristics

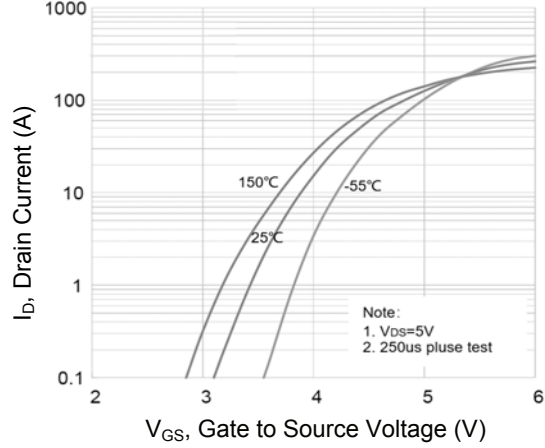

Figure 2. Transfer Characteristics

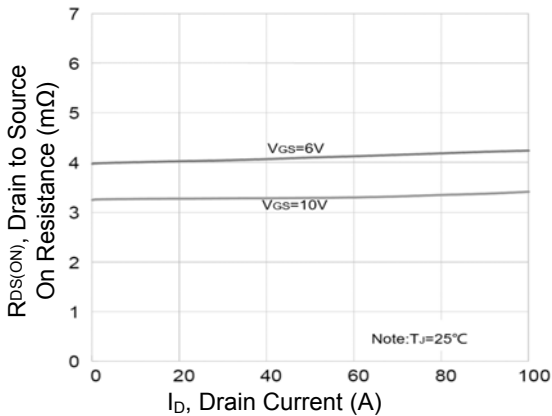

Figure 3. $R_{DS(ON)}$ vs. Drain Current

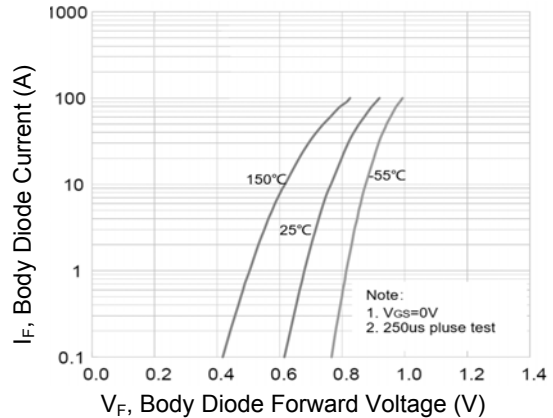

Figure 4. Body Diode Characteristics

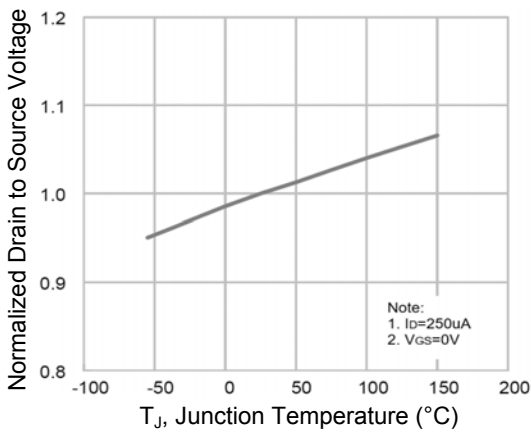

Figure 5. Normalized BV_{DSS} vs. T_J

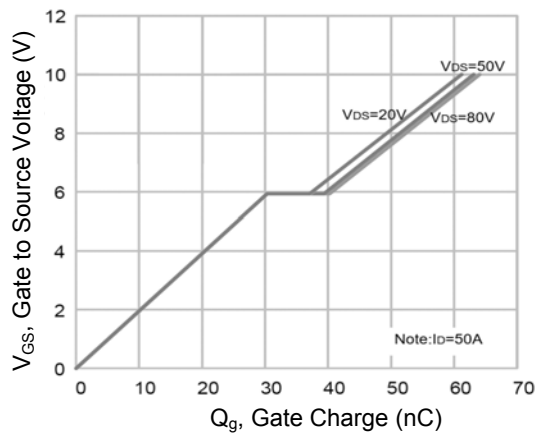

Figure 6. Gate Charge Characteristics

Typical Electrical and Thermal Characteristic Curves

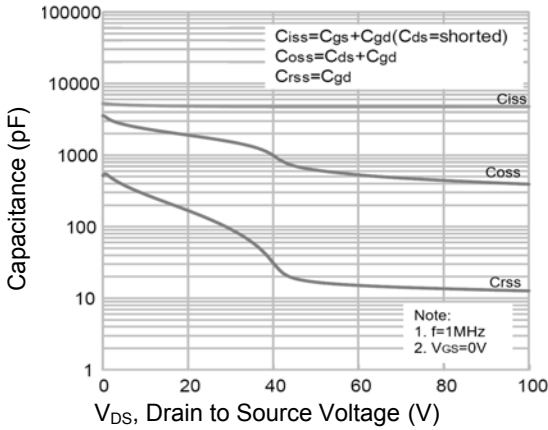

Figure 7. Capacitance Characteristics

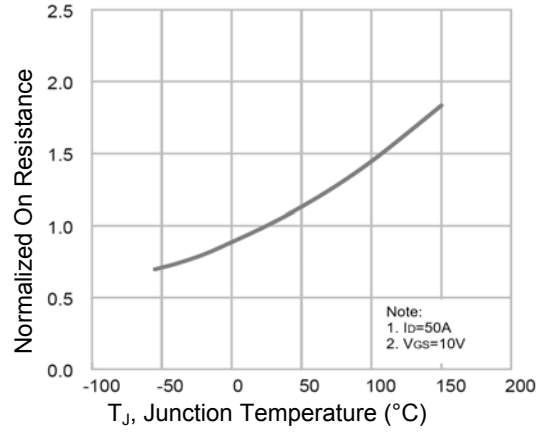

Figure 8. Normalized $R_{DS(ON)}$ vs. T_J

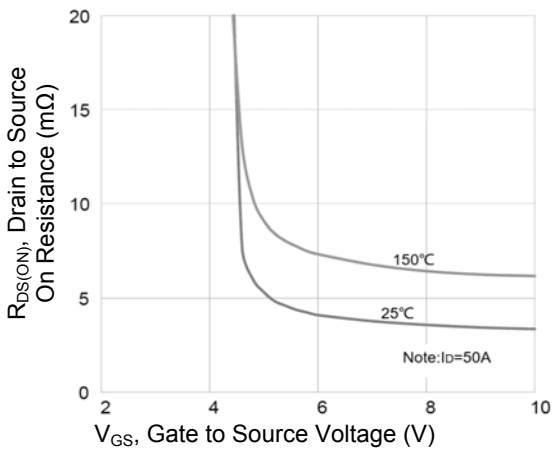

Figure 9. $R_{DS(ON)}$ vs. V_{GS}

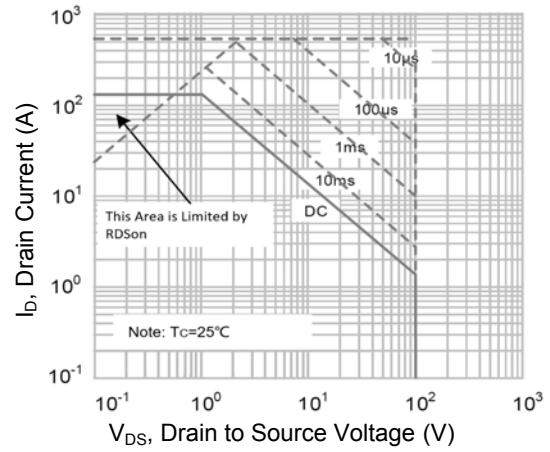
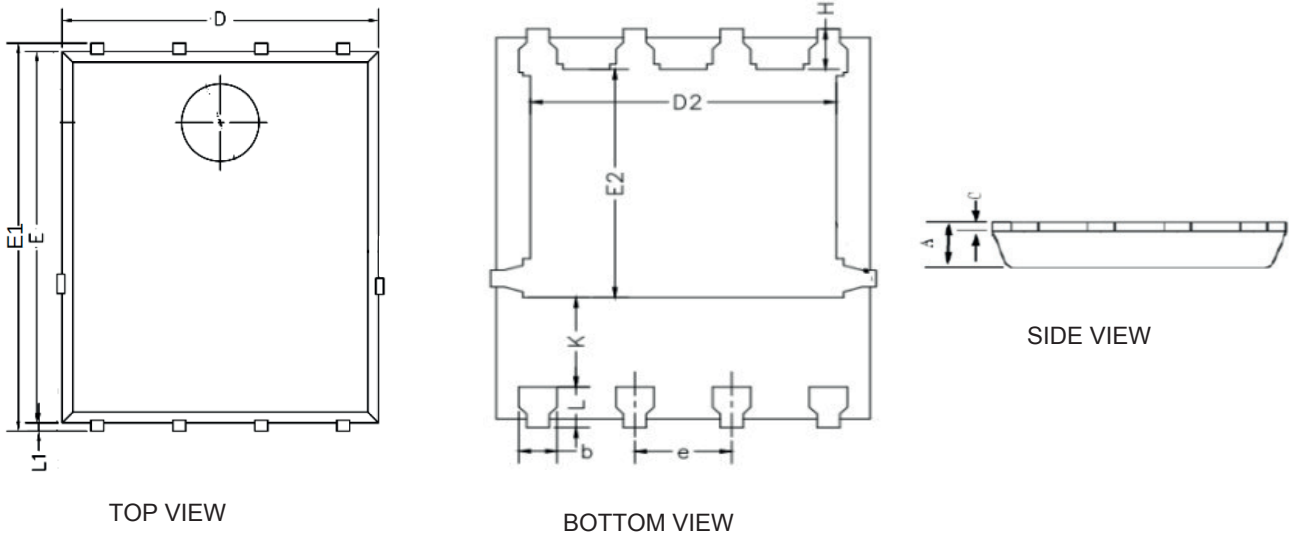

Figure 10. Safe Operation Area

Package Outline Dimensions (PPAK5x6)



Symbol	Dimensions In Millimeters		Dimensions In Inches	
	Min.	Max.	Min.	Max.
A	0.90	1.20	0.035	0.047
b	0.30	0.55	0.012	0.022
C	0.15	0.35	0.006	0.014
D	4.70	5.20	0.185	0.205
D2	3.76	4.20	0.148	0.165
E2	3.30	3.85	0.130	0.152
E	5.60	5.90	0.220	0.232
E1	5.80	6.20	0.228	0.244
K	1.10	-	0.043	-
H	0.45	0.75	0.018	0.030
L	0.45	0.75	0.018	0.030
L1	0.25	0.45	0.010	0.018
e	1.27 BSC		0.050 BSC	

Order Information

Device	Package	Marking	Carrier	Quantity
GSFP4R310	PPAK5x6	P4R310	Tape & Reel	5,000 Pcs / Reel

For more information, please contact us at: inquiry@goodarksemi.com