

Main Product Characteristics

V_{DSS}	-30 V
$R_{DS(ON)}$	10.6 m Ω (typ.)
I_D	-12A

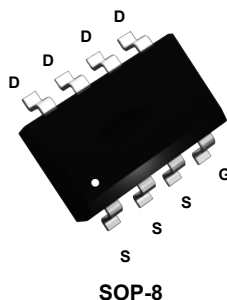

SOP-8

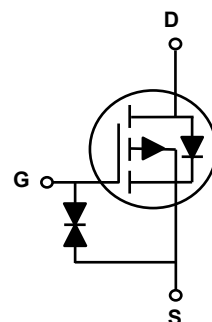

Schematic Diagram

Features and Benefits

- Advanced trench MOSFET process technology
- Ideal for PWM, load switching and general purpose applications
- Ultra low on-resistance with low gate charge
- Fast switching and reverse body recovery
- 150°C operating temperature



Description

The SSF3611E utilizes the latest techniques to achieve high cell density and low on-resistance. These features make this device extremely efficient and reliable for use in high efficiency switch mode power supply and a wide variety of other applications.

Absolute Maximum Rating

Symbol	Parameter	Max.	Unit
$I_D @ T_C = 25^\circ\text{C}$	Continuous Drain Current, $V_{GS} @ 10\text{V}$ ①	-12	A
$I_D @ T_C = 100^\circ\text{C}$	Continuous Drain Current, $V_{GS} @ 10\text{V}$ ①	-7.4	
I_{DM}	Pulsed Drain Current②	-48	
$P_D @ T_C = 25^\circ\text{C}$	Power Dissipation③	2	W
V_{DS}	Drain-Source Voltage	-30	V
V_{GS}	Gate-to-Source Voltage	± 20	V
T_J, T_{STG}	Operating Junction and Storage Temperature Range	-55 to +150	$^\circ\text{C}$

Thermal Resistance

Symbol	Characteristics	Typ.	Max.	Unit
$R_{\theta JA}$	Junction-to-Ambient ($t \leq 10\text{S}$) ④	—	62.5	$^\circ\text{C}/\text{W}$



Electrical Characteristics ($T_A=25^\circ\text{C}$ unless otherwise specified)

Symbol	Parameter	Min.	Typ.	Max.	Unit	Conditions
$V_{(BR)DSS}$	Drain-to-Source Breakdown Voltage	-30	—	—	V	$V_{GS} = 0V, I_D = 250\mu A$
$R_{DS(ON)}$	Static Drain-to-Source On-resistance	—	10.6	13	m Ω	$V_{GS} = -10.0V, I_D = -10.0A$
		—	14.1	16		$V_{GS} = -4.50V, I_D = -7.50A$
$V_{GS(th)}$	Gate threshold Voltage	-1	—	-2	V	$V_{DS} = V_{GS}, I_D = 250\mu A$
I_{DSS}	Drain-to-Source Leakage Current	—	—	-1	μA	$V_{DS} = -30V, V_{GS} = 0V$
I_{GSS}	Gate-to-Source Forward Leakage	—	—	10	μA	$V_{GS} = 20V$
		—	—	-10		$V_{GS} = -20V$
Q_g	Total Gate Charge	—	55	—	nC	$I_D = -10A,$ $V_{DS} = -25V,$ $V_{GS} = -10V$
Q_{gs}	Gate-to-Source Charge	—	3.5	—		
Q_{gd}	Gate-to-Drain("Miller") Charge	—	18	—		
$t_{d(on)}$	Turn-on Delay Time	—	8.0	—	nS	$V_{GS} = -10V, V_{DS} = -15V,$ $R_L = 15\Omega,$ $R_{GEN} = 3\Omega$
t_r	Rise Time	—	5.8	—		
$t_{d(off)}$	Turn-Off Delay Time	—	56	—		
t_f	Fall Time	—	38	—		
C_{iss}	Input Capacitance	—	3224	—	pF	$V_{GS} = 0V$ $V_{DS} = -15V$ $f = 1MHz$
C_{oss}	Output Capacitance	—	459	—		
C_{rss}	Reverse Transfer Capacitance	—	425	—		

Source-Drain Ratings and Characteristics

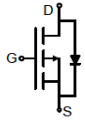
Symbol	Parameter	Min.	Typ.	Max.	Unit	Conditions
I_S	Continuous Source Current (Body Diode)	—	—	-12	A	MOSFET symbol showing the integral reverse p-n junction diode. 
I_{SM}	Pulsed Source Current (Body Diode)	—	—	-48	A	
V_{SD}	Diode Forward Voltage	—	-0.73	-1.2	V	$I_S = -2.1A, V_{GS} = 0V$
t_{rr}	Reverse Recovery Time	—	16	—	nS	$T_J = 25^\circ\text{C}, I_F = -10A, di/dt = 100A/\mu s$
Q_{rr}	Reverse Recovery Charge	—	5.9	—	μC	

Test Circuits and Waveforms

EAS test circuits:

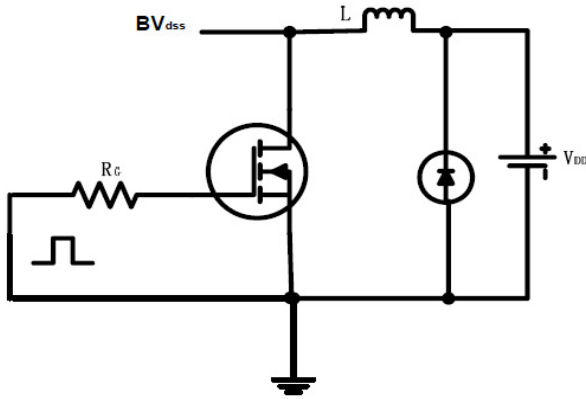

Gate charge test circuit:

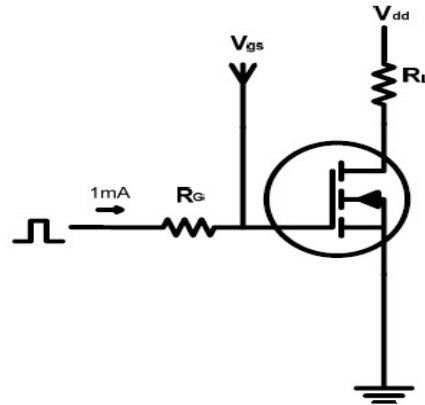

Switch time test circuit:

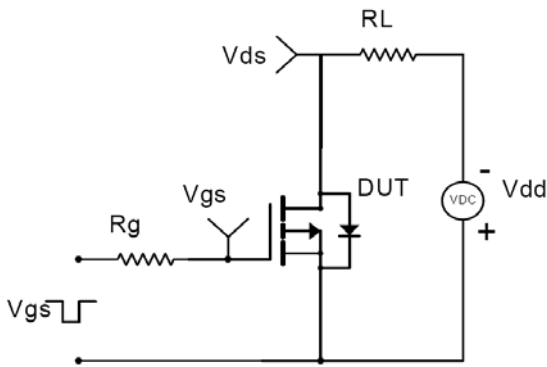

Switching Waveforms

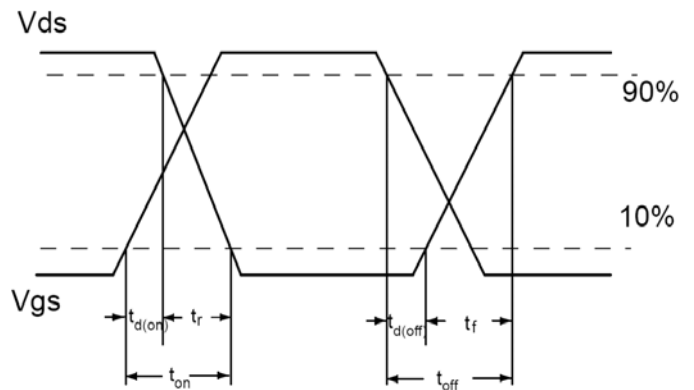

Notes:

- ① The maximum current rating is limited by bond-wires.
- ② Repetitive rating; pulse width limited by max. junction temperature.
- ③ The power dissipation P_D is based on max. junction temperature, using junction-to-ambient thermal resistance.
- ④ The value of $R_{\theta JA}$ is measured with the device mounted on 1in² FR-4 board with 2oz. Copper, in a still air environment with $T_A = 25^\circ\text{C}$

Mechanical Data

SOP-8 PACKAGE OUTLINE DIMENSION

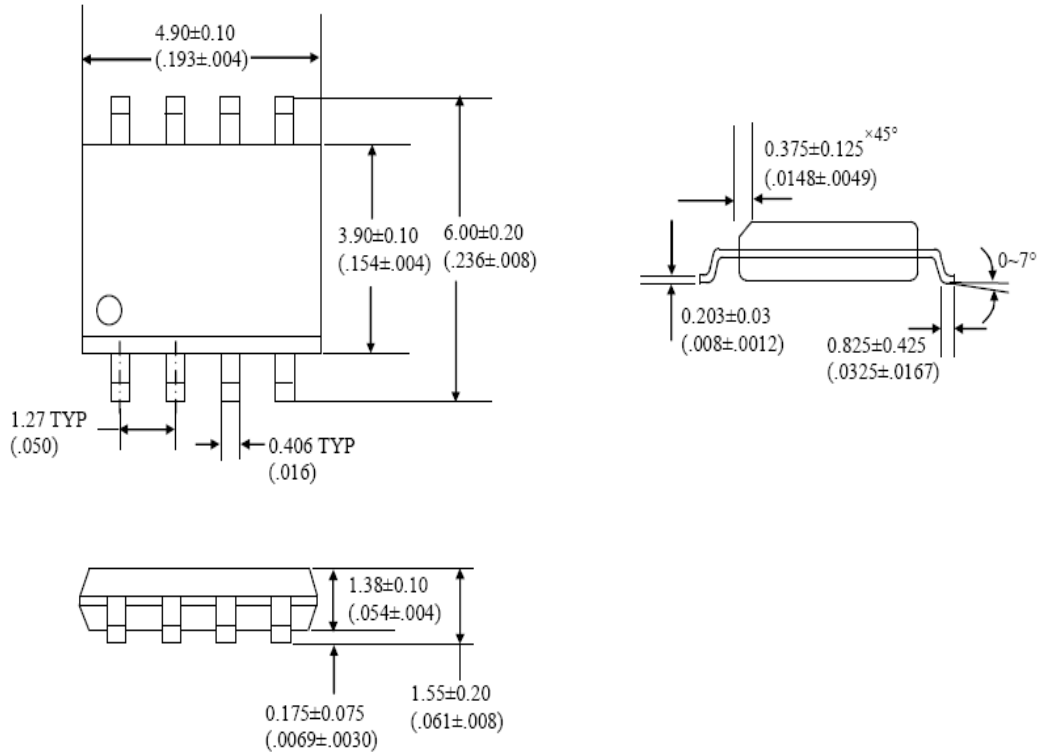

Symbol	Dimension In Millimeters		Dimension In Inches	
	Min	Max	Min	Max
A	1.350	1.750	0.053	0.069
A1	0.100	0.250	0.004	0.010
A2	1.280	1.480	0.050	0.058
b	0.406		0.016	
c	0.173	0.233	0.007	0.009
D	4.800	5.000	0.189	0.197
E	3.800	4.000	0.150	0.157
E1	5.800	6.200	0.228	0.244
e	1.27TYP		0.050TYP	
L	0.400	1.250	0.016	0.050

Ordering and Marking Information

Device Marking: SSF3611E

Package (Available)
SOP-8
Operating Temperature Range
C : -55°C to +150 °C

Devices per Unit

Package Type	Units/Tape	Tapes/Inner Box	Units/Inner Box	Inner Boxes/Carton Box	Units/Carton Box
SOP-8	2500	2	5000	8	40000

Reliability Test Program

Test Item	Conditions	Duration	Sample Size
High Temperature Reverse Bias(HTRB)	$T_J=125^{\circ}\text{C}$ or 150°C @ 80% of Max $V_{DSS}/V_{CES}/V_R$	168 hours 500 hours 1000 hours	3 lots x 77 devices
High Temperature Gate Bias(HTGB)	$T_J=125^{\circ}\text{C}$ or 150°C @ 100% of Max V_{GSS}	168 hours 500 hours 1000 hours	3 lots x 77 devices