

GBU1001 thru GBU1010

General Purpose Bridge Rectifiers
 Reverse Voltage 100V to 1000V Forward Current 10.0A

Features

- Plastic package has Underwriters Laboratory Flammability Classification 94V-0
- Glass passivated chip junction
- High current capability
- Low forward voltage drop
- High temperature soldering guaranteed: 260°C/10 seconds at terminals
- Component in accordance to RoHS 2015/863/EU

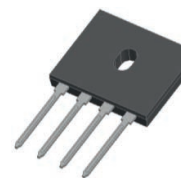

GBU

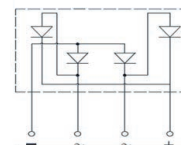

Schematic Diagram

Mechanical Data

- Case: GBU molded plastic body
- Terminals: Plated leads solderable per MIL-STD-750, method 2026
- Mounting position: Any

Applications

Used in AC/DC bridge full wave rectification for SMPS, lighting ballaster, adapter, charger, home appliances, office equipment, and telecommunication applications.

Maximum Ratings and Electrical Characteristics

(Rating at 25°C ambient temperature unless otherwise specified. Single phase, half wave, resistive or inductive load. For capacitive load, derate current by 20%.)

Parameters	Symbol	GBU 1001	GBU 1002	GBU 1004	GBU 1006	GBU 1008	GBU 1010	Units
Maximum Reverse Peak Reverse Voltage	V_{RRM}	100	200	400	600	800	1000	V
Maximum RMS Voltage	V_{RMS}	70	140	280	420	560	700	V
Maximum DC Blocking Voltage	V_{DC}	100	200	400	600	800	1000	V
Maximum Average Forward Rectified Current, (See Fig 2)	$I_{F(AV)}$	10.0						A
Peak Forward Surge Current 8.3ms Single Half Sine-Wave Superimposed on Rated Load	I_{FSM}	220						A
Rating for Fusing (t=8.3ms)	I^2t	200						A ² S
Maximum Instantaneous Forward Voltage at 5.0A DC	V_F	1.00						V
Maximum DC Reverse Current at Rated DC Blocking Voltage	$T_J=25^\circ\text{C}$	5						μA
	$T_J=125^\circ\text{C}$	100						μA
Typical Junction Capacitance ¹	C_J	60						pF
Typical Thermal Resistance, Junction-Ambient ²	$R_{\theta JA}$	25						°C/W
Typical Thermal Resistance, Junction-Case ²	$R_{\theta JC}$	2.2						°C/W
Operating Temperature Range	T_J	-55 to +150						°C
Storage Temperature Range	T_{STG}	-55 to +150						°C

Notes:

1. Measured at 1MHz and applied reverse voltage of 4.0 Volts.
2. Unit mounted on 100mm x 100mm x 1.6mm copper plate heatsink.

Ratings and Characteristics Curves

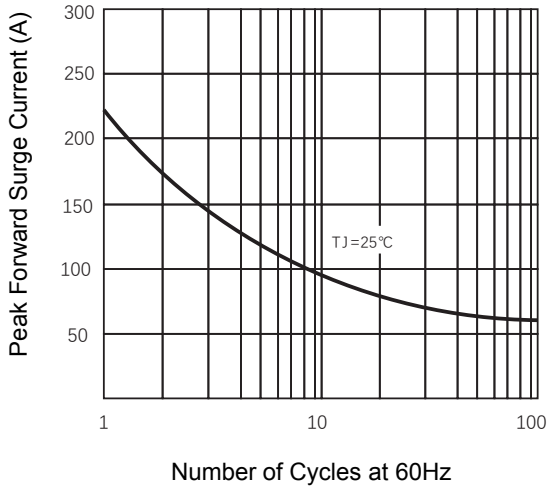

Figure 1. Maximum Forward Surge Current

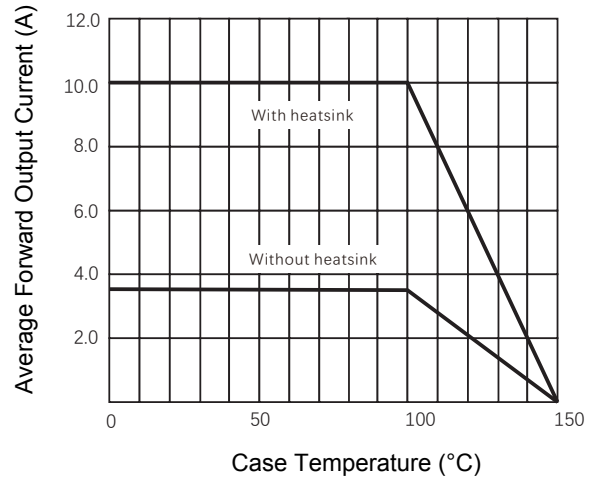

Figure 2. Forward Current Derating Curve

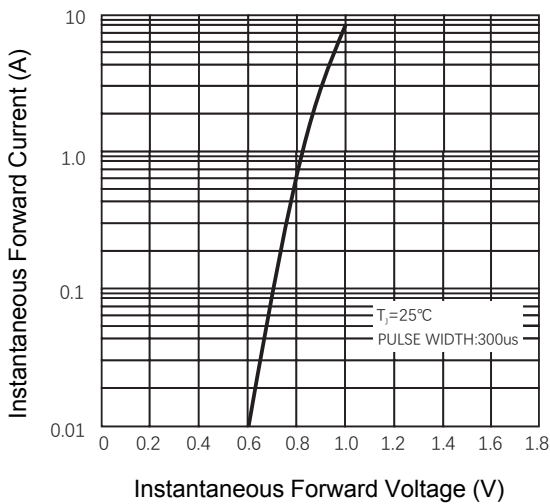

Figure 3. Typical Forward Characteristics

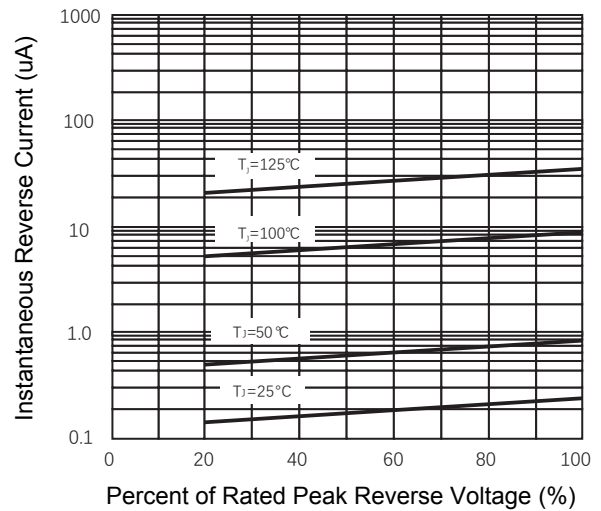
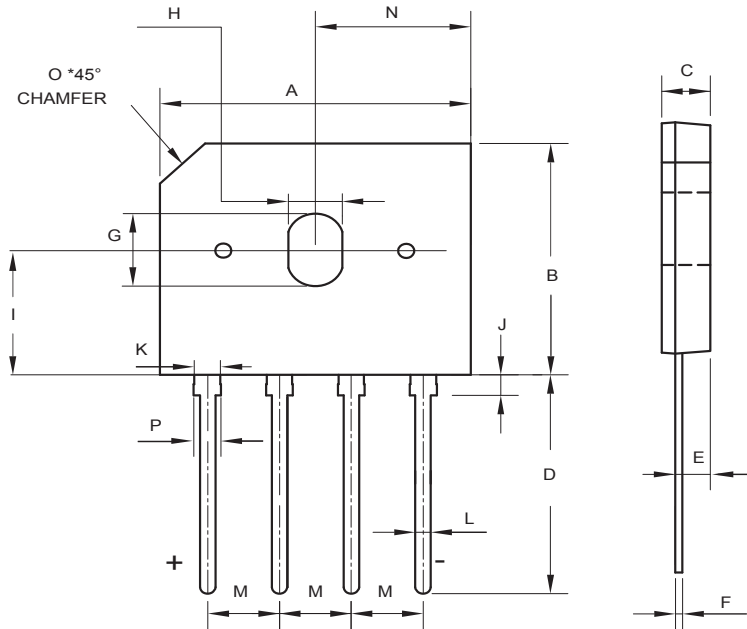

Figure 4. Typical Reverse Characteristics

Package Outline Dimensions (GBU)



Symbol	Dimensions In Millimeters		Dimensions In Inches	
	Min.	Max.	Min.	Max.
A	21.80	22.20	0.858	0.874
B	18.30	18.70	0.720	0.736
C	3.35	3.55	0.132	0.140
D	17.50	18.50	0.689	0.728
E	2.30	2.70	0.091	0.106
F	0.48	0.58	0.019	0.023
G	5.10	6.00	0.201	0.236
H	3.30	4.00	0.130	0.157
I	9.50	10.50	0.374	0.413
J	1.90	2.60	0.075	0.102
K	2.05	2.25	0.081	0.089
L	1.10	1.30	0.043	0.051
M	4.83	5.33	0.190	0.210
N	10.90	11.10	0.429	0.437
O	3.20 TYP		0.126 TYP	
P	2.15	2.35	0.085	0.093

Order Information

Device	Package	Marking	Packaging	SPQ
GBU1001	GBU	GBU1001	Tube	20 Pcs / Tube
GBU1002	GBU	GBU1002	Tube	20 Pcs / Tube
GBU1004	GBU	GBU1004	Tube	20 Pcs / Tube
GBU1006	GBU	GBU1006	Tube	20 Pcs / Tube
GBU1008	GBU	GBU1008	Tube	20 Pcs / Tube
GBU1010	GBU	GBU1010	Tube	20 Pcs / Tube

For more information, please contact us at: inquiry@goodarksemi.com